

LEOMI[®]
— OPTIMIZING LIFE —

$$q=h\Delta T$$

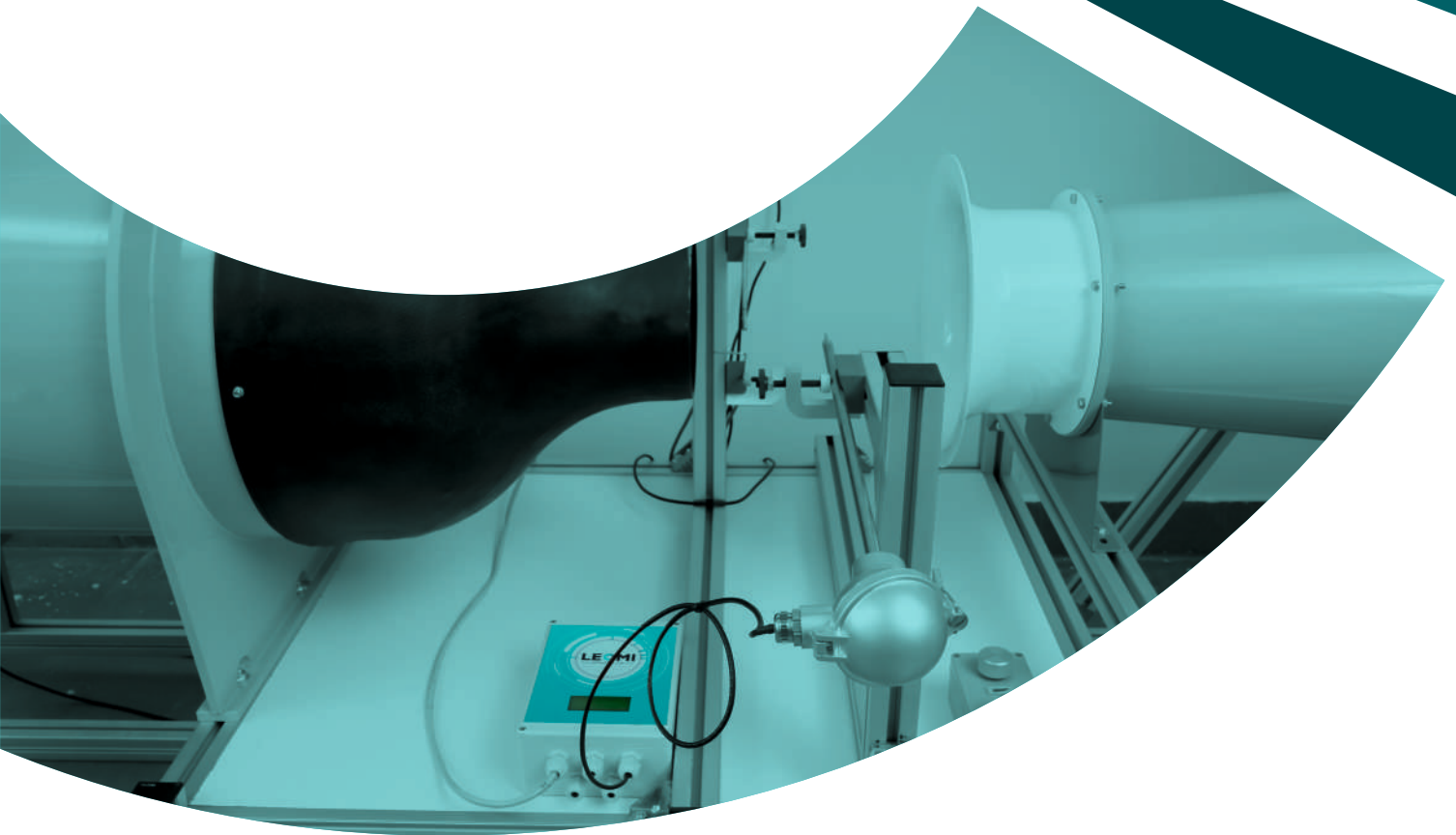

Manufacturer of Insertion Thermal Mass
Flowmeter for Compressed Air & Process Gases

GERMAN TECHNOLOGY ENGINEERED IN INDIA

ABOUT US

A continuous endeavour of more than two decades into the field of technologies and automation has inspired LEOMI Founders to start a manufacturing venture looking into the industrial measurement solutions that optimizes life. LEOMI provides affordable and reliable solutions with the hands on expertise of MTS Engineers Pvt Ltd that has fuelled reputed companies for industry specific technologies. LEOMI strive to hunt industries' rugged applications for optimization of industrial processes with German technology transfer from growth engine of India, Gujarat.

MISSION



Developing measurement instruments to optimize life of industrial processes & equipments

INTEGRITY



We embrace values of our stakeholders by remaining transparent and ethical in our dealings

PRACTICAL



We understand and adaptive to real situations of our stakeholders for our business actions

RESPONSIBLE



We responsibly conduct business considering socio-economic needs

HOLISTIC



We accept holistic approaches in collaboration with our stakeholders for betterment of humanity

INNOVATIVE



Our team engages in providing innovative solutions by working upon customer's pain areas consciously

OPTIMIZING LIFE OF PROCESS, MACHINE AND EQUIPMENT

LEOMI 586

Insertion Thermal Mass Flow Meter

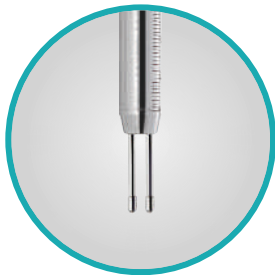

SS 316Ti without
Safety Head

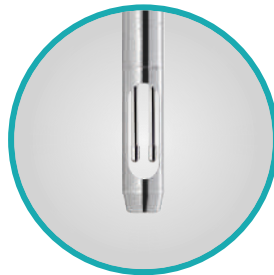

SS 316Ti with
Safety Head

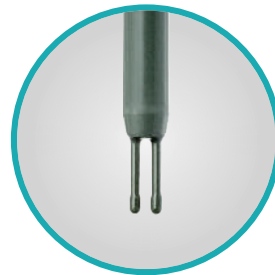

HALAR® Coated

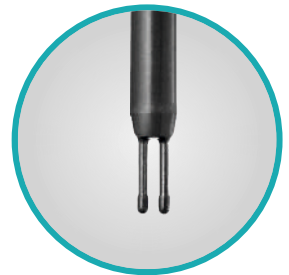

PFA Coated

FEATURES

- No moving parts
- Wide measuring ranges allow the detection of leakage & increases in consumption
- Measuring mass flow rate independent of pressure and temperature variations
- High accuracy throughout temperature ranges up to 400°C
- Operates in any positions
- Programmable pipe diameters from 15mm to 10000mm
- Probes with $\varnothing=12\text{mm}$ & Length up to 2000 mm available
- Circular, Square, Rectangular and other ducts mounting possible
- Easy Installation & maintenance
- HALAR® & PFA coated probes for highly corrosive gases available
- Integration in data network with different data converters possible
- In-built terminal software with gas volume, gas mixture & insertion depth calculators

MEASUREMENT PRINCIPLE
THERMAL DISPERSION TECHNIQUE

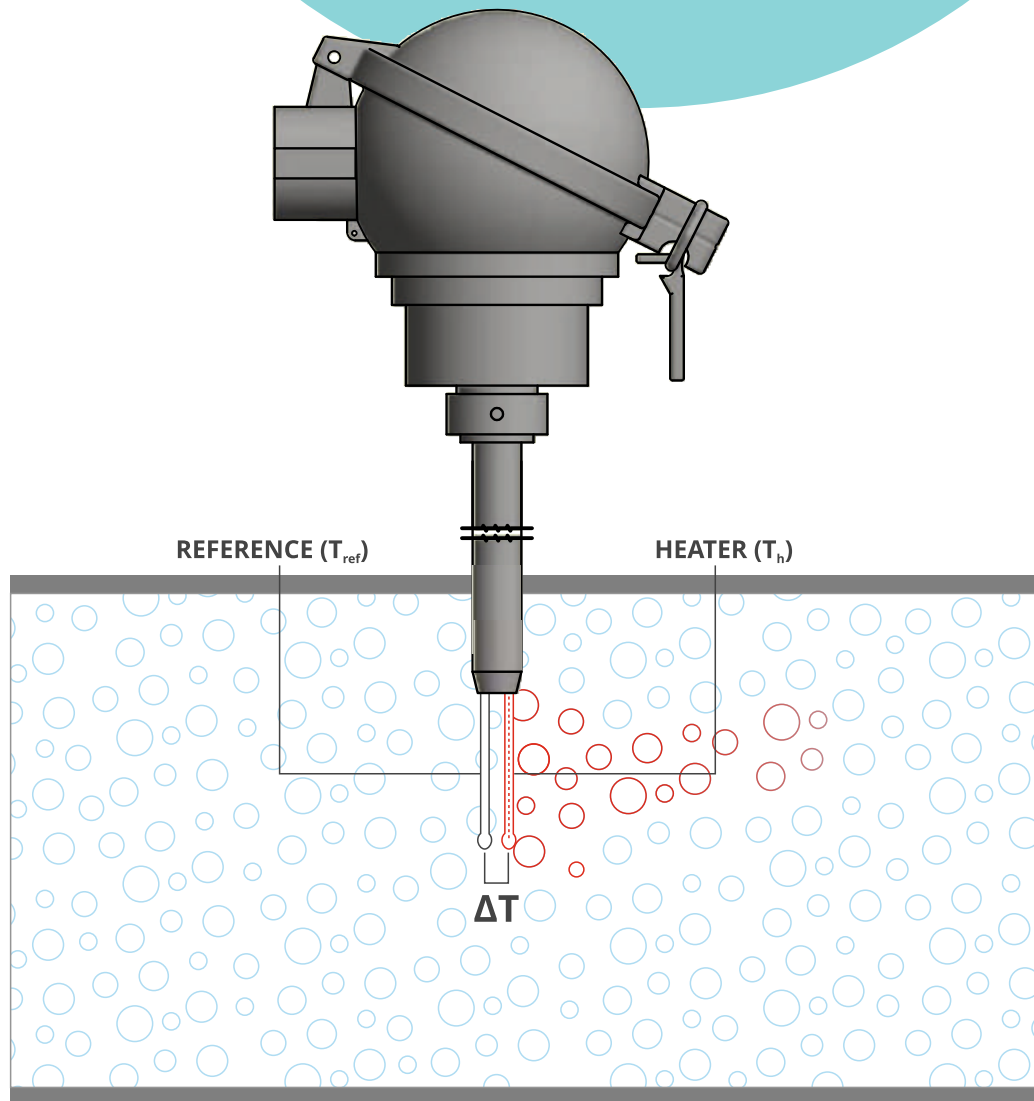

Constant Temperature Anemometry (CTA)
(Digital controlled Circuit not Wheatstone bridge)

LEOMI-586

LEOMI-586 Thermal Mass (Calorimetric) Flow Meter works on the physical principle of thermal dispersion from a heated element to the ambient medium (example: air or gases). This is affected by the velocity, density (temperature and pressure) and by the characteristic of the medium. The amount of needed energy is a function of the temperature difference ΔT and the mass flow.

Gas flowing through two RTD Pt-100 one reference (T_{ref}) and other Heater (T_h). The temperature difference (over-temperature) Δt between the reference sensor (medium temperature) and the heater sensor is controlled constantly. As per **King's Law**, higher the mass flow rate, higher the cooling effect of the heater sensor, thus higher the power required to maintain the differential temperature constant. Therefore the heater power is proportional to the gas mass flow rate.

SENSOR TECHNICAL SPECIFICATION

Sensor Details	: 2 X Pt-100 RTD Sensor Element (4-wire Technique) Diameter :12mm / 25mm (Optional) Length : 250mm; 500mm; 1000mm (Other upon request)
Sensor Material	SS-316Ti (DIN1.4571); HALAR® & PFA Coating for corrosive gases (optional) (Other consult factory)
Fluids	Air & Gases
Flow Range	: 0.6 – 65 Nm/s (Turndown 100:1); 0.6 -150 Nm/s (optional with extrapolation above 65 Nm/s.) (As per DIN 1343; 0°C/1.01325 bar(a),0%RH)
Accuracy (%)*	: ±1.5% reading (-40°C-100°C); ±2.0% reading (0°C - 200°C / 300°C / 400°C) at reference calibration conditions upto 75 m/s
Repeatability (%):	±0.5% of reading
Response time t90	: <1.5secs
Operating temperature	: -40°C to +100°C, 0 - 200°C; 0 -300°C; 0 - 400°C
Operating pressure	: 16bar(g) Max. PN16 (Higher upon request)
Ambient temperature:	-40°C to +80°C
Process connection	: ½" NPT (M) SS-316 Compression Ferrule (Other upon request)
Ingress Protection	: IP67

* Calorimetric flow sensors normally needed no service, however, electronic components get under influence of growing older and changing its electrical characteristics. Changing of the coating by corrosion and pollution could also influence the accuracy. So it is necessary, from time to time (recommendation: about every 2 years) to check the calibration.

Note: Technical specifications and dimensions subject to change due to continuous research and development

SIGNAL TRANSMITTER TECHNICAL SPECIFICATIONS

Remote Signal Transmitter	: Microprocessor based, complete and automatic compensation of temperature conditioned signal drifting. Digital conductivity compensated adjustment of the heater over temperature
Power Supply	: 24VDC (18 - 36VDC) OR 100 – 265 VAC@50Hz
Power Consumption	: < 5 watts
Display	: 16 X 4 LCD Backlit Display
Measuring Unit	: Mass flowrate (Kg/hr) & Totalizer (Kg); Volume flowrate (Nm ³ /Hr or SCFM) & Totalizer (Nm ³ or SCF) & Process Temperature (°C)
Outputs	: 0/4-20 mADC (Isolated @600Ω) OR 0 -10VDC flowrate proportional 1 NO / NC Relay contact @ 250VAC / 6A programmable for Temperature OR flowrate; RS-232 Modbus Bi-directional for data transmission & configuration via LEOMI 586.1.0.0 Terminal Software Opto coupler impulse output, other data converters available on request
Ambient Temperature	: -20°C to +60°C
Ingress Protection	: IP 65/ IP66 OR IP67 (Optional) (Other consult factory)
Enclosure Protection	: Flameproof Gas Group IIA, IIB, T4 (Optional) (Other consult factory)
Enclosure Details	: ABS Plastic 200mm(L) x 150mm(W) x 79mm(D); Aluminium Diecast (Optional) 260mm(L) x 160mm(W) x 91mm(D) (Other upon request)

LEOMI 586

Part No.														
0500 0586	S	2	3	Y	A	1	1	R	1	C	M	1	P	0

1	Probe MOC													
	S	SS 316 Ti (1.4571)												
	H	SS 316 Ti (1.4571) with HALAR® Coating - Upto 75°C												
	P	SS 316 Ti (1.4571) with PFA Coating - Upto 175°C												
2	Length													
	2	250 mm												
	5	500 mm												
	8	1000 mm												
	9	Other (Please Specify)												
3	Temperature													
	1	100°C												
	2	200°C												
	3	300°C												
	4	400°C												
4	Probe Sensor Protection													
	N	Without Safety Head												
	Y	With Safety Head												
5	Probe Head Junction Box MOC													
	A	Aluminium Die Cast												
	9	Other												
6	Probe Connection													
	1	Compression Ferrule - 1/2" NPT												
	9	Other												
7	Cable													
	1	5 Mtrs												
	2	10 Mtrs												
	3	20 Mtrs												
	4	30 Mtrs												
	9	Other												
8	Transmitter													
	R	Remote												
9	Input Power Supply													
	1	24 VDC												
	2	100 - 265 VAC@50Hz												
10	Analogue Output													
	C	4-20 mA DC (Isolated@600Ω)												
	V	0-10 VDC												
11	Digital Output													
	M	RS 232 Modbus Bi-Directional												
	9	Other												
12	Alarm Output													
	1	Relay Output												
13	Enclosure MOC													
	P	ABS Plastic												
	A	Aluminium Die Cast												
	F	Aluminium Die Cast - Flameproof												
14	Probe Accessories													
	0	NA												
	1	Ball Valve												
	2	Safety Chain												
	9	Other												

CALIBRATION

CALIBRATION FACILITY

India's first In-house latest state-of-the-art made in Germany fully automatic Göttinger calibration wind tunnel DKD certified as per ISO-17025 DAkkS traceability for Air Velocity ranges 0.2 m/s to 75 m/s with flow uniformity of $\pm 0.2\%$.

CALIBRATION SERVICES

LEOMI provides calibration services for other manufacturers of various types of Air velocity Instruments such as Insertion Thermal Mass Flowmeter, Hot-wire & Vane Anemometer, Pitot Tubes etc.

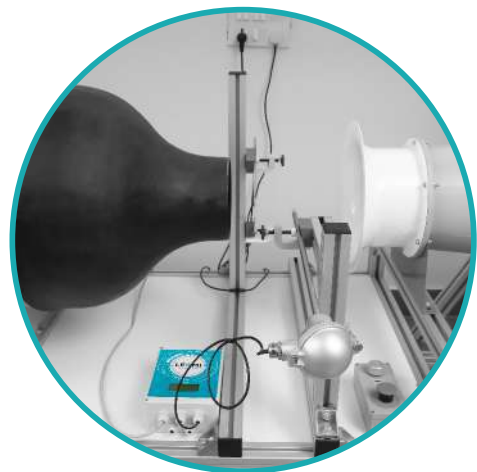

APPLICATIONS

CHEMICAL & PETROCHEMICALS



Process Gas, Flare Gas, Compressed Air, Natural Gas, Combustion Air, Aeration Air

CEMENT & FERTILIZERS



Co₂ Gas, Compressed Air, Natural Gas, Combustion Air, Flue Gas, Process Gas, Aeration Air

TEXTILE INDUSTRY



Compressed Air, Natural Gas, Combustion Air, Aeration Air

FOOD & PHARMACEUTICALS



Compressed Air, Natural Gas, Aeration Air, Biogas

AUTOMOBILE & ANCILLARIES



Compressed Air, Natural Gas, Welding Gases

STEEL & POWER



Fluegas, Blast Furnace Gas, Combustion Air, Compressed Air, Natural Gas, Welding Gas



5866.0.0

LEOMI INSTRUMENTS PVT. LTD.

E-17/5, Electronic GIDC, Sector-26,
Gandhinagar-382027, Gujarat, INDIA.

☎ +91 79 23287899, +91 90547 50586

✉ sales@leomi.in

🌐 www.leomi.in

AUTHORISED DEALER